

ITEM	P.N.	DESCRIPTION	QTY
------	------	-------------	-----

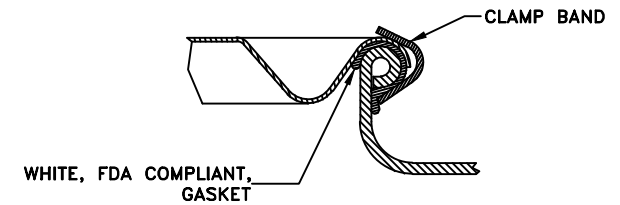

DRUM NECK SECTION

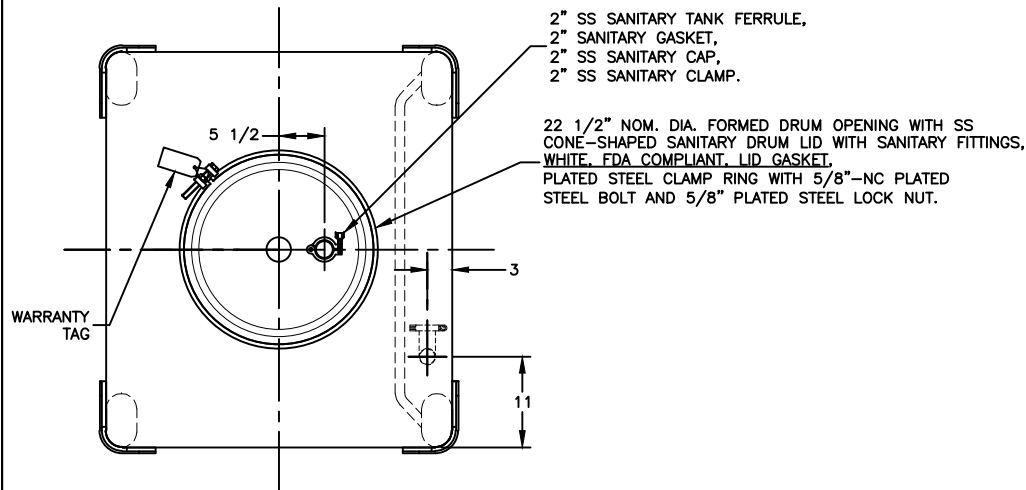
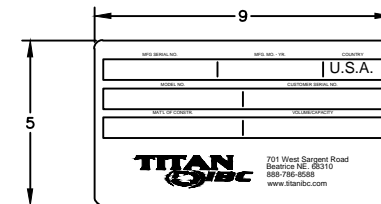
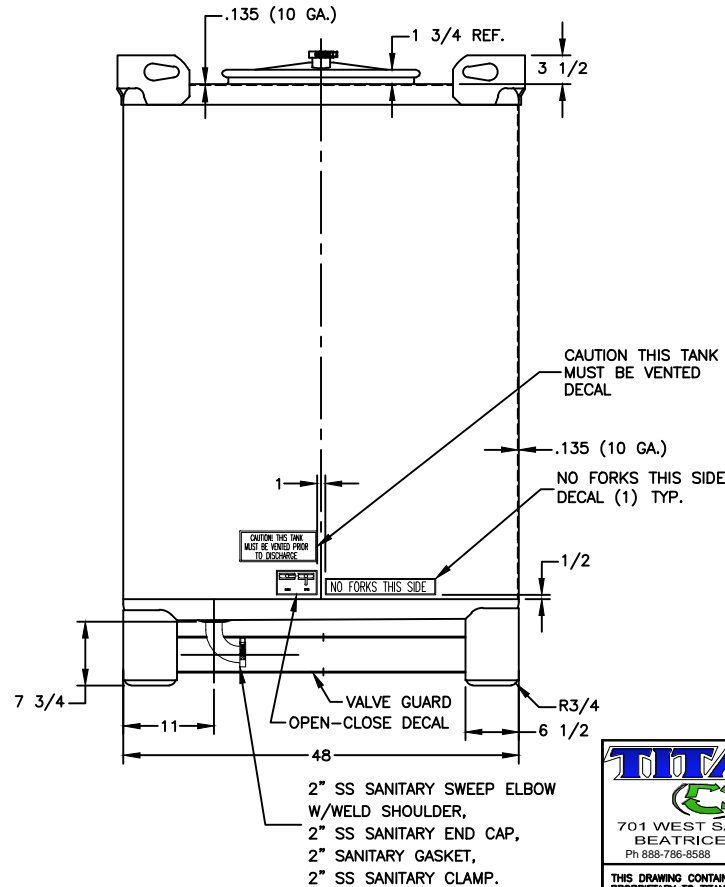
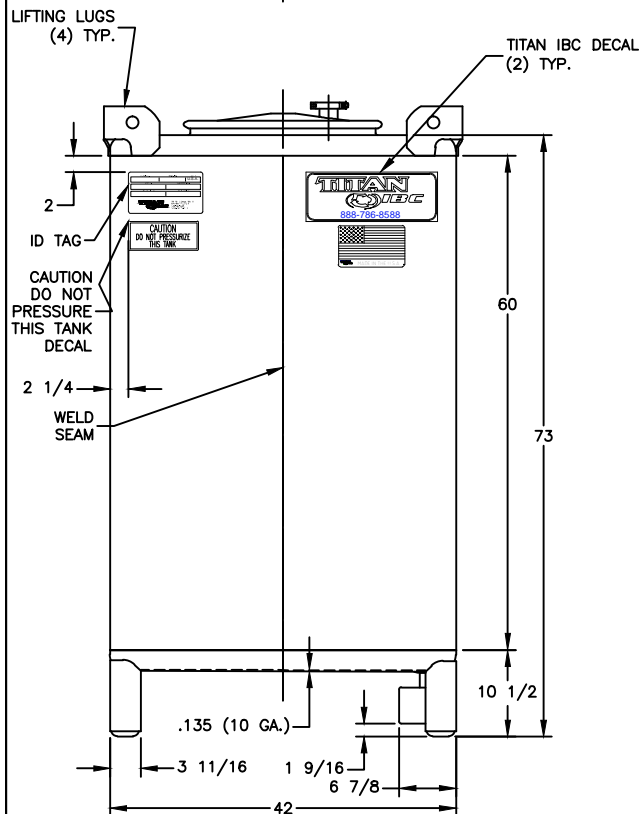

ID TAG DETAIL

CUSTOMER DRAWING APPROVAL STATUS	
<input type="checkbox"/>	APPROVED AS SHOWN. PROCEED WITH FABRICATION.
<input type="checkbox"/>	APPROVED AS NOTED. REVISE DWG & PROCEED WITH FABRICATION.
<input type="checkbox"/>	NOT APPROVED ! REVISE DWG AS MARKED & RESUBMIT DWG FOR APPROVAL.
SIGNATURE: _____	
DATE: _____	

- NOTE:
- REMOVE ALL BURRS, SHARP EDGES AND WELD DISCOLORATION.
 - TANK TO HAVE 2" NOMINAL RADIUS CORNERS.
 - BOTTOM SLOPES TOWARD OUTLET FOR OPTIMUM DRAINAGE.
 - PRODUCT CONTACT ZONE TO BE 304 SS ALLOY, 2B FINISH.
 - TANKS WILL STACK AND TOP LIFT.
 - TANKS TO BE LEAK PROOF TESTED TO 3PSIG.
 - PLASTIC BAG IS TO BE PUT OVER THE TANK PRIOR TO SHIPMENT. NOT SHOWN ON DRAWING.
 - ALL CORNERS ARE ONE PIECE SEAMLESS (BULLNOSE).
 - INTERIOR WELDS TO BE STRIP CLEANED.
 - EXTERIOR WELDS TO BE STRIP CLEANED.



DESCRIPTION:
**550 GAL SS NON-UN
BASE WINE TANK**

DWG BY: LAS	APPROVED BY:
DATE: 4/2/14	DRAWING NO: 110498
SCALE: 1:10	MAT'L: 304 SS
REVISION NO. NONE	

REV.	DESCRIPTION	DATE	BY
------	-------------	------	----